

ECT362	INTRODUCTION TO MEMS	CATEGORY	L	T	P	CREDIT
		PEC	2	1	0	3

Preamble: This course introduces students to the rapidly emerging, multi-disciplinary, and exciting field of Micro Electro Mechanical Systems.

Prerequisite: EST130-Basics of Electrical and Electronics Engineering, EST 100-Engineering Mechanics

Course Outcomes

CO1	Describe the working principles of micro sensors and actuators
CO2	Identify commonly used mechanical structures in MEMS
CO3	Explain the application of scaling laws in the design of micro systems
CO4	Identify the typical materials used for fabrication of micro systems
CO5	Explain the principles of standard micro fabrication techniques
CO6	Describe the challenges in the design and fabrication of Micro systems

Mapping of course outcomes with program outcomes

	PO1	PO2	PO3	PO4	PO5	PO6	PO7	PO8	PO9	PO10	PO11	PO12
CO1	3	3										
CO2	3	3										
CO3	3	3										
CO4	3	3	2									
CO5	3	3										
CO6	3	3										

Assessment Pattern

Bloom's Category	Continuous Assessment Tests		End Semester Examination
	1	2	
Remember	10	10	20
Understand	30	30	60
Apply	10	10	20
Analyse			
Evaluate			
Create			

Mark distribution

Total Marks	CIE	ESE	ESE Duration
150	50	100	3 hours

Continuous Internal Evaluation Pattern:

Attendance	: 10 marks
Continuous Assessment Test (2 numbers)	: 25 marks
Assignment/Quiz/Course project	: 15 marks

End Semester Examination Pattern: There will be two parts; Part A and Part B. Part A contain 10 questions with 2 questions from each module, having 3 marks for each question. Students should answer all questions. Part B contains 2 questions from each module of which student should answer any one. Each question can have maximum 2 sub-divisions and carry 14 marks.

Course Level Assessment Questions

Course Outcome 1 (CO1): Describe the working principles of micro sensors and actuators

1. Explain the principle of operation of two types of micro-accelerometers
2. Explain with relevant examples how the principle of electrostatics may be used for the design of MEMS based sensors and actuators.
3. Explain how smart materials can be used for the design of MEMS based sensors and actuators.

Course Outcome 2 (CO2): Identify commonly used mechanical structures in MEMS

1. Explain the purpose of micro cantilevers in MEMS systems. What is the relevance of spring constant (k) of a mechanical structure in micro system design?
2. Derive the expression for the magnitude of applied bending moment with reference to pure bending of longitudinal beams.
3. Explain how plates and diaphragms can be used for the design

Course Outcome 3(CO3): Explain the application of scaling laws in the design of micro systems

1. Explain force scaling vector, what information does it provide to a MEMS designer?
2. Derive equations for acceleration a , time t and power density P/V based on the Trimmer Force Scaling Vector?
3. Explain why electrostatic actuation is preferred over electromagnetic actuation at the micro-scale.

Course Outcome 4 (CO4): Identify the typical materials used for fabrication of micro systems

1. State the relevant properties of Silicon Carbide and Silicon Nitride for use in Microsystems.
2. Explain why Silicon evolved as the ideal substrate material for MEMS fabrication.
3. Explain with examples the advantages of use of polymers in micro systems fabrication?

Course Outcome 5 (CO5): Explain the principles of standard micro fabrication techniques

1. Explain the steps involved in photolithography. State the chemicals used in each of the stages along with the operating conditions.
2. Explain the criteria for choice of surface or bulk micromachining techniques in the design of micro systems.
3. Explain with block diagram the steps in LIGA process. State two advantages of LIGA process over other micro machining techniques.

Course Outcome 6 (CO6): Describe the challenges in the design, fabrication and packaging of Micro systems

1. Explain the challenges involved in the packaging of Microsystems as compared to microelectronic devices
2. Discuss the various fabrication challenges associated with surface micromachining.

SYLLABUS**MODULE I**

MEMS and Microsystems: Applications – multidisciplinary nature of MEMS – principles and examples of Micro sensors and micro actuators – micro accelerometer –comb drives - Micro grippers – micro motors, micro valves, micro pumps, Shape Memory Alloys.

Actuation and Sensing techniques: Thermal sensors and actuators, Electrostatic sensors and actuators, Piezoelectric sensors and actuators, magnetic actuators

MODULE II

Review of Mechanical concepts: Stress, Strain, Modulus of Elasticity, yield strength, ultimate strength – General stress strain relations – compliance matrix. Overview of commonly used mechanical structures in MEMS - Beams, Cantilevers, Plates, Diaphragms – Typical applications

Flexural beams: Types of Beams, longitudinal strain under pure bending – Deflection of beams – Spring constant of cantilever – Intrinsic stresses

MODULE III

Scaling laws in miniaturization - scaling in geometry, scaling in rigid body dynamics, Trimmer force scaling vector, scaling in electrostatic and electromagnetic forces, scaling in electricity and fluidic dynamics, scaling in heat conducting and heat convection.

Materials for MEMS – Silicon – Silicon compounds – Silicon Nitride, Silicon Dioxide, Silicon carbide, Poly Silicon, GaAs , Silicon Piezo resistors. Polymers in MEMS – SU-8, PMMA, PDMS, Langmuir – Blodgett Films.

MODULE IV

Micro System fabrication – Photolithography – Ion implantation- Diffusion – Oxidation – Chemical vapour deposition – Etching

Overview of Micro manufacturing – Bulk micro manufacturing, Surface micro machining , LIGA process –Microstereo lithography

MODULE V

Micro system Packaging: general considerations in packaging design – Levels of Micro system packaging. Bonding techniques for MEMS: Surface bonding, Anodic bonding, Silicon - on - Insulator, wire bonding, Sealing – Assembly of micro systems.

Overview of MEMS areas : RF MEMS, BioMEMS, MOEMS, NEMS

Text Books:

1. Chang Liu, Foundations of MEMS, Pearson 2012
2. Tai-Ran Hsu, MEMS and Microsystems Design and Manufacture, TMH, 2002

Reference Books:

1. Chang C Y and Sze S. M., VLSI Technology, McGraw-Hill, New York, 2000
2. Julian W Gardner, Microsensors: Principles and Applications, John Wiley & Sons, 1994
3. Mark Madou, Fundamentals of Micro fabrication, CRC Press, New York, 1997
4. Stephen D. Senturia, Microsystem design, Springer (India), 2006.
5. Thomas B. Jones, Electromechanics and MEMS, Cambridge University Press, 2001
6. Gregory T.A. Kovacs, Micromachined Transducers Sourcebook, McGraw Hill, 1998

Course Contents and Lecture Schedule

No	Topic	No. of Lectures
1.1	Introduction to MEMS and Microsystems	1
1.2	Applications – multidisciplinary nature of MEMS – principles and examples of Micro sensors and micro actuators – micro accelerometer, comb drives -	1
1.3	Micro grippers – micro motors,	1
1.4	micro valves, micro pumps, Shape Memory Alloys.	1
1.5	Actuation and Sensing techniques : Thermal sensors and actuators,	1
1.6	Electrostatic sensors and actuators	1
1.7	Piezoelectric sensors and actuators,	1
1.8	magnetic actuators	1

2.1	Review of Mechanical concepts: Stress, Strain, Modulus of Elasticity, yield strength, ultimate strength	1
2.2	General stress strain relations – compliance matrix.	1
2.3	Overview of commonly used mechanical structures in MEMS - Beams, Cantilevers, Plates, Diaphragms – Typical applications	1
2.4	Flexural beams: Types of Beams, longitudinal strain under pure bending	2
2.5	Deflection of beams – Spring constant of cantilever, Intrinsic stresses	1
3.1	Scaling laws in miniaturization - scaling in geometry, scaling in rigid body dynamics, Trimmer force scaling vector,	2
3.2	scaling in electrostatic and electromagnetic forces	1
3.3	scaling in electricity and fluidic dynamics,	1
3.4	scaling in heat conducting and heat convection	1
3.5	Materials for MEMS – Silicon – Silicon compounds- Silicon Nitride	1
3.6	Silicon Dioxide, Silicon carbide	1
3.7	Poly Silicon, GaAs , Silicon Piezo resistors	1
3.8	Polymers in MEMS – SU-8, PMMA,	1
3.9	PDMS, Langmuir – Blodgett Film	1
4.1	Micro System fabrication,Photolithography– Ion implantation	2
4.2	Diffusion, Oxidation	1
4.3	Chemical vapour deposition, Etching	1
4.4	Overview of Micro manufacturing – Bulk micro manufacturing,	1
4.5	Surface micro machining	1
4.6	LIGA process	1
4.7	Microstereo lithography	1
5.1	Micro system Packaging: general considerations in packaging design	1
5.2	Levels of Micro system packaging	1
5.3	Bonding techniques for MEMS : Surface bonding , Anodic bonding	1
5.4	Silicon - on - Insulator , wire bonding	1
5.5	Sealing – Assembly of micro systems	1
5.6	Overview of MEMS areas : RF MEMS, BioMEMS, MOEMS, NEMS	1

A P J Abdul Kalam Technological University
Sixth Semester B Tech Degree Examination
Course: ECT 362 Introduction to MEMS
Time: 3 Hrs Max. Marks: 100

PART A

Answer All Questions

- | | | |
|----|--|---|
| 1 | State an example to justify the multidisciplinary nature of MEMS | 3 |
| 2 | State three applications of MEMS devices in the automotive industry | 3 |
| 3 | Define normal stress and strain, how it is different from shear stress and strain | 3 |
| 4 | Determine the stress in the longitudinal direction of a Silicon rod with rectangular cross section is pulled on both ends with a force of 10mN. The dimensions of the rod being 1 mm X 100 μ m X 50 μ m. | 3 |
| 5 | Define the Trimmer force scaling vector | 3 |
| 6 | State one application each of PDMS and PMMA in MEMS fabrication | 3 |
| 7 | Discuss the criteria for selecting materials for the masks used in etching | 3 |
| 8 | Define etch stop? State the different methods used to stop etching | 3 |
| 9 | State the various levels of micro system packaging | 3 |
| 10 | State two applications of NEMS | 3 |

PART B

Answer one question from each module. Each question carries 14 marks.

Module I

- | | | |
|-------|--|---|
| 11(A) | Sketch and explain the working of a silicon capacitive accelerometer attached to a comb drive | 6 |
| 11(B) | Explain the operating principle of piezoelectric sensors and actuators with relevant sketches. | 8 |

OR

- | | | |
|-------|--|---|
| 12(A) | Explain the operating principle of thermal bimorphs with neat sketches. State any two applications of thermal sensors. | 8 |
| 12(B) | Explain the principle of operation of the following micro sensors (i) Comb drives (ii) Shape Memory Alloys | 6 |

Module II

- | | | |
|-------|---|---|
| 13(A) | Determine the force constant associated with the two beams (a) and (b) shown in figure below. Which is stiffer, justify with arguments. | 8 |
|-------|---|---|

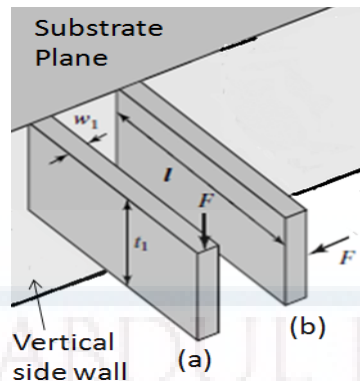

- 13(B) Explain with neat sketches the longitudinal strain experienced by segment of beam (with rectangular cross-section) under pure bending. 6

OR

- 14(A) Explain the general stress strain relationship and arrive at the compliance matrix 8
- 14(B) Explain with neat sketches the type of mechanical beams and boundary conditions associated with supports 6

Module III

- 15(A) Explain in the light of scaling, assuming a 10 times reduction of size of the actuator. Which of the electrostatic and electromagnetic forces are best suited for micro device actuation. 8
- 15(B) State three relevant properties of Silicon Carbide and Silicon Nitride for use in Microsystems 6

OR

- 16(A) Explain various scaling laws in miniaturization 6
- 16(B) State the constraints in pumping fluids in micro channels. What pumping scheme is usually used in micro fluidics, state one example? 8

Module IV

- 17(A) Explain the steps involved in photolithography. State the chemicals used in each of the stages along with the operating conditions 6
- 17(B) Compare and contrast various micro manufacturing techniques 8

OR

- 18(A) Describe the various mechanical problems associated with surface micromachining 6
- 18(B) Explain the LIGA process associated with MEMS fabrication 8

Module V

- 19(A) Explain the following bonding techniques with figures a) Silicon-on-Insulator b) Wire bonding 8
- 19(B) Explain the challenges involved in BioMEMS. List three applications of BioMEMS. 8

OR

- 20(A) Explain with diagrams any two applications of RFMEMS 8
- 20(B) Explain the challenges involved in designing packages for micro systems 6

